



# Praktikumsversuch

# Control of the Motion of Optical Lenses

## MOTIVATION

- ❖ understanding and applying conventional concepts of control theory such as the Kalman-Bucy filter
- ❖ collecting experience with Matlab-Simulink as a programming platform for embedded microcontrollers and real-time system control
- ❖ advanced operation of laboratory devices for measurements and actuation

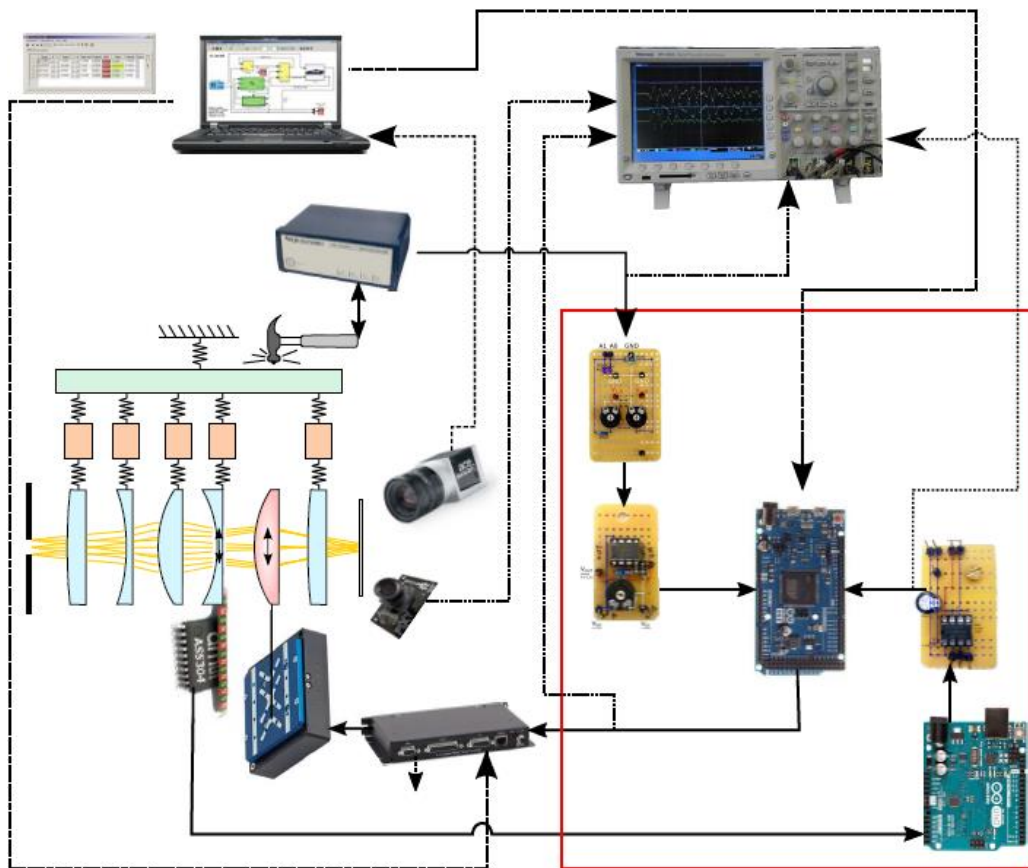
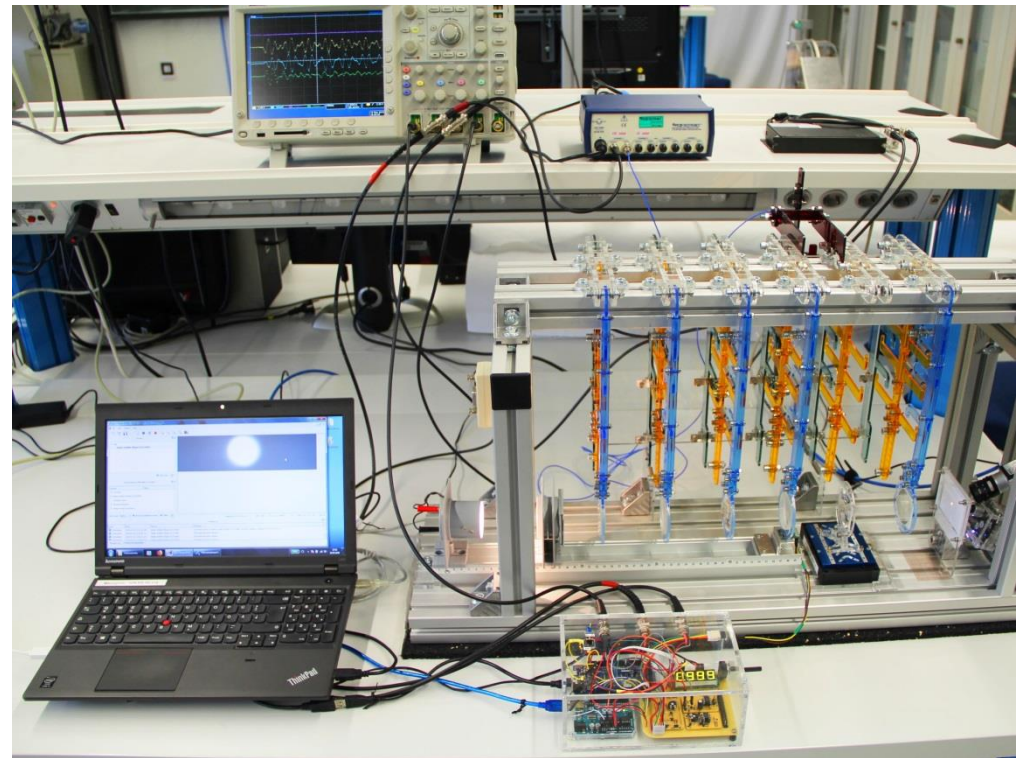

## PROCEDURE

1. getting acquainted with the experimental setup in future integration mode, which compensates for image vibrations using active control of optics
2. comparison of the results using an oscilloscope
3. deploying software on the Arduino-based control unit for changing the control system to feed forward mode
4. changing the stiffness matrix of the system to observe the effects of model parameter variation

## EXPERIMENTAL SETUP

- ❖ 12 DOF multibody system with 6 lenses
- ❖ compensating lens mounted on a high precision linear actuator
- ❖ oscilloscope for measurements and notebook for model deployment
- ❖ Pixy cam for real-time image processing
- ❖ control unit based on Arduino boards

